

Production of Poly- V profiles



characteristics

- available profiles PH, PJ, PK, PL, PM
- in conveyor and timing belt surfaces
- material: PU, PVC and rubber
- different constructions

Poly-V pull off belt

- special production for cable, pipes and profiles
- endless cord
- PVC coating on both sides

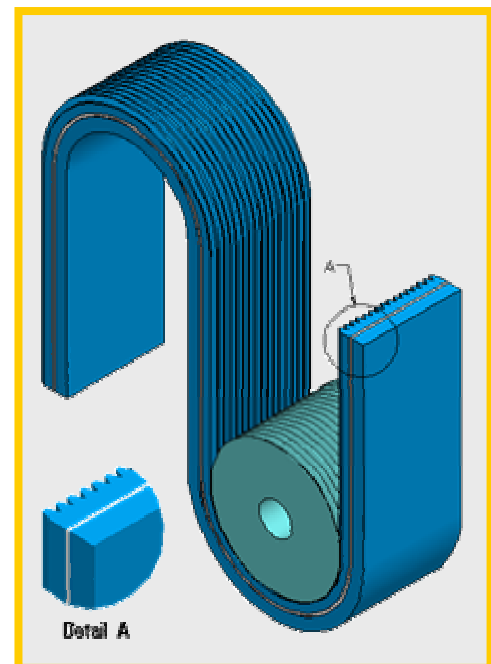
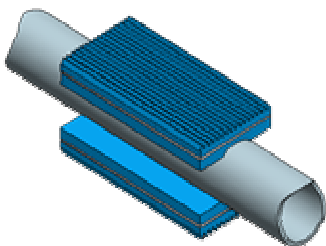

PU-Poly-V belt

- in flex- or welded construction
- little abrasion
- FDA- quality possible

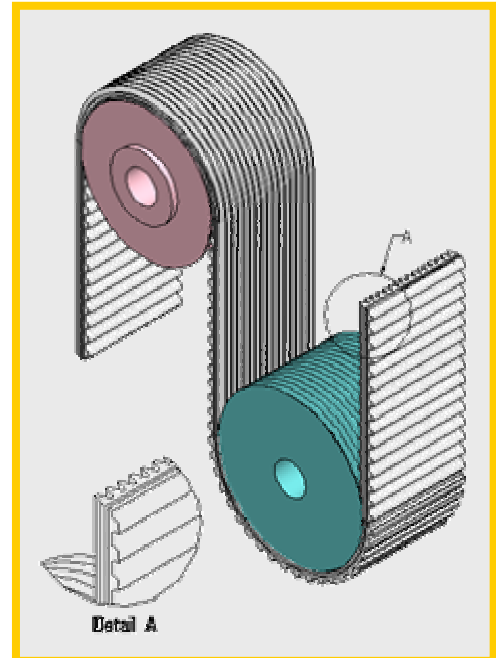

PU-Poly-V belt combined with timing belt

- in flex- or welded construction
- little abrasion
- FDA- quality possible
- all pitches possible

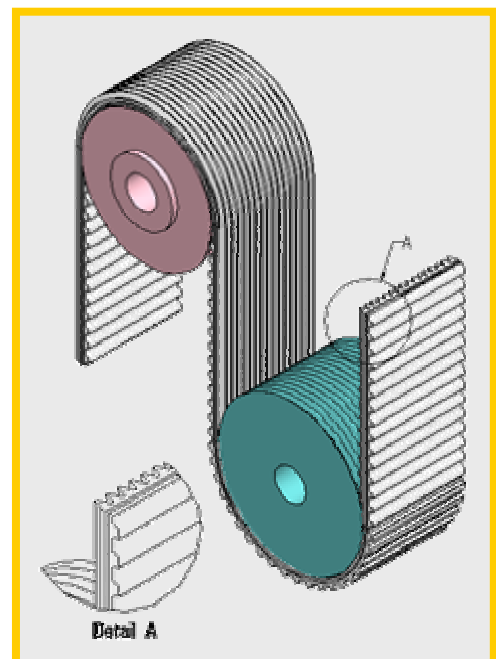

from timing belt to Poly- V- belt

- post- milling of Poly-V-Profiles in the teeth of timing belts

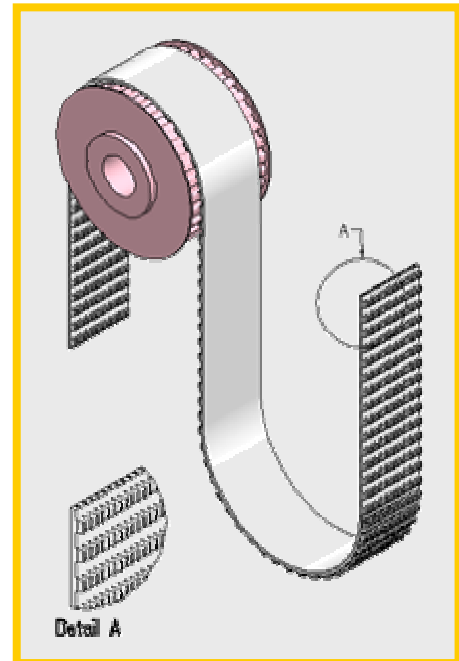

V- belt with Poly- V- Profile on the back

- post- milling of Poly-V-Profiles in the back of a V- belt

