

Coating • Processing • Cams • Special solutions

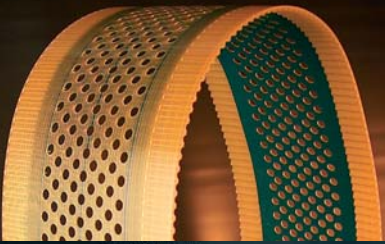

Producer of custom conveyor and function belts

Industry leader
in transport belt
technology

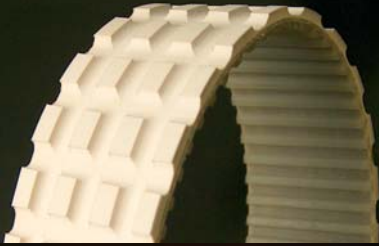
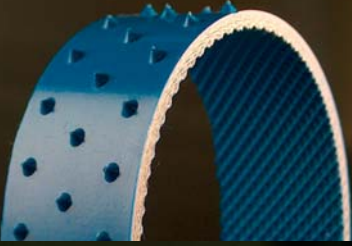



Ordering example, inches

Length Cog Width Fabric/Cord Coating

Neo-timing belt 270L200 Glas cord - Sleeve / Linatex 6mm

27 · 25,4mm = 685,8 mm long

2 · 25,4mm = 50,8 mm wide

Ordering example, millimeters

PU-timing belt 100 T10 / 1440 Kevlar - V / Silicone 2mm

100 mm wide

1440 mm long

Explanation of color coding for ordering examples.

Belt Width

Cog pitch

Length

Coating

Fabric / cord

Cut pieces in metre (M) / welded (V) / (W)

The information in this catalogue is based on our experience and knowledge at the time of writing. Considering the variety of possible influences on our products during their processing and use the information does in no way release customers of carrying out their own examinations and testing. No binding legal warranty regarding particular characteristics or the aptitude for a specific application can be derived from our information. Any property rights as well as existing laws and regulations must be observed by the recipient of our products at their own responsibility.

Subject to alterations due to technical developments or adaptations to changed norms or regulations.

Photographs shown in this catalogue are examples for demonstration and are not

binding for the final finish of the goods supplied.

All prices available on request.

Address:

Norditec Antriebstechnik GmbH
Kiekut

D-19258 Zahrendorf

Phone: +49 (0)38847- 624810

Fax: +49 (0)38847- 624814

e-mail: kontakt@norditec.de

Internet: www.norditec.de

Norditec USA LLC

6427 Ithaca Lane North

Minneapolis, Minnesota 55311-4148

Phone: 763-550-9063

Fax: 763-550-0506

e-mail: kroll@norditec-usa.com

Internet: www.norditec-usa.com

Contents

Our Company	2
Product range	3
Coatings	4
Polyurethane	5
Rubber	6
PVC	8
Other Coatings	9
Special Coatings	10
Silicone Coating	10
APLN Coating	10
Teflon Coating	10
Seamless PU Coating	10
Felt Coating	11
FDA Approved Coatings	12
Coated V-belts	13
Ridgetop V-belts	13
Processing	14
Dual Timing Belts	15
Vacuum Timing Belts	16
Cam Belts	17
Removable-Cam System	18
Pocket Timing Belts	19
Technological Special Solutions	20
Wide PU Timing belts	20
Magnetic Timing belts	21
Water-Jet Cutting Technology	22
Timing Belt Robotics	22
Detachable Belt Fasteners	23
Equipment and Appliances	23
Portable Cutting Machine	23
Portable Welding Press	23
Commercial Goods	23
Timing Belts	23
Toothed Washer	23
Poly-Net	23
Services	24
Water-Jet Cutting	24
Polyurethane Spraying	24
Anti-Static Measurement	24

About us

Norditec Antriebstechnik Germany was founded in 1994 when it started coating timing belts. Over the years, with the help of its dedicated team, Norditec has developed into a leading supplier of special conveyor belts.



On a production area of 11,000 ft² (3,000 m²) 60 employees produce customer-specific conveyor belts such as cam-belts, coated belts and belts treated with mechanical CNC-technology. Our already versatile product range is continuously expanding and as a result this brochure can only give you a global overview of our possibilities. Feel free to ask! Our R&D department is eager to develop new and innovative solutions in conjunction with our customer.

Our determined product and technology development and the improvement of traditional methods ensures our success.



Being awarded the Ludwig-Bölkow-Technology Award for the development of an endless silicone coating and the application for several patents also speaks for the innovative nature of the company.



From the headquarters in Germany and our Office in the U.S. we supply to over 40 countries around the world. With our fast processing we make sure delivery times remain as short as possible.



Our product range

The manufacturing of all our products is based on the purchase of industrially produced drive belts such as; timing belts, Poly-V belts, V-belts and belts that are refined into special conveyor belts.



Important basic equipment at Norditec includes:

- PU spraying facilities
- Vulcanising technology (presses and autoclaves)
- Water-jet cutting technology
- CNC-machines
- Construction department and mechanical workshop for quick construction of production equipment
- State-of-the-art plastics joining technology
- Silicone coating equipment
- Comprehensive belt grinding and coating machines

Customization Techniques

- Open ended and endless coating
- Mechanical CNC processing
- Cam welding
- Special solutions

There is almost no limit to our capabilities to customize belts. If you have a special application and are looking for a solution, please contact us.

In addition to the refining of timing belts Norditec offers the following services:

Equipment and Tooling

- Welding presses
- Portable belt cutting machines

Services

- Water-jet cutting
- PU spraying
- Measurement of electric conductivity

Standard components

- Toothed pulley
- Belts



Coatings



Norditec offers an extensive range of coatings. Different coatings can be used to achieve the desired conveying characteristics. These include: high or low friction, soft, hard or elastic surfaces. The application of a soft synthetic foam to the belt surface, for example, can help protect the product, while the application of a heat resistant felt coating can protect the belt from heat when hot products need to be transported.

The belt can be further treated either on the transport side or the toothed side. Slots can be cut into very thick coatings to improve flexibility. A „V-guide“ can be attached to the toothed side to improve tracking. Kevlar can be added to reduce wear, impregnated magnets can be added, butt or seamless joint, the possibilities are endless.

Application methods

Coatings can be applied to the belts in the following ways:

- Welding
- Gluing
- Vulcanizing
- Spraying

Multiple different layers of coatings are also possible. A silicone-sealed green Polyurethane coating is shown below.

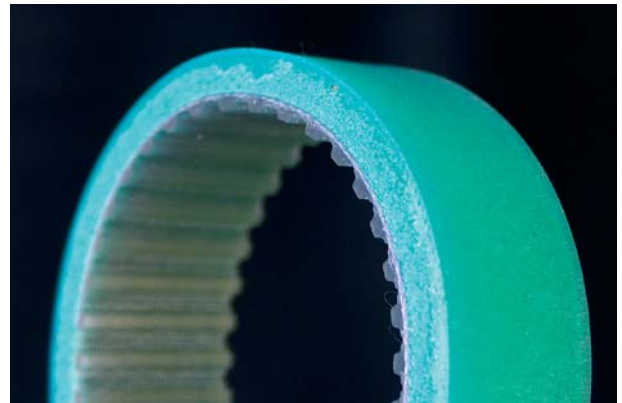

Many of our belt coatings are shown on the following pages. If a coating is not listed, please call us. Our coating inventory is steadily expanding and a sample coating will be sent upon request.

Polyurethane (PU)

Sylomer (PU Foam)

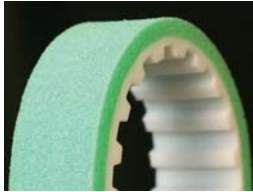

Yellow Type G: VW: 150 kg/m³
 Blue Type R: VW: 220 kg/m³
 Green Type L: VW: 300 kg/m³
 Brown Type M: VW: 400 kg/m³
 Red Type P: VW: 510 kg/m³
 Grey Type V: VW: 680 kg/m³

Celloflex



Vulkolan foam
 Yellow-brown
 VW: 400 kg / m³

PU Foil, clear / HV sheet



Clear
 Hardness: 85° Shore

Vulkolan D15



Yellow-brown
 Hardness: 70° Shore

PU Foil D44



Brown
 Hardness: 72° Shore

PU Foil FDA



White
 Hardness: 90° Shore

PU Grip

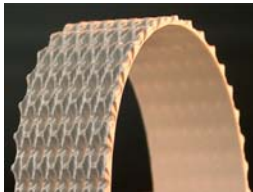

White

PU Foil



White, hardness: 60° Shore
 Milky, hardness: 85° Shore
 Natural, hardness: 92° Shore
 Blue

PU Nipple

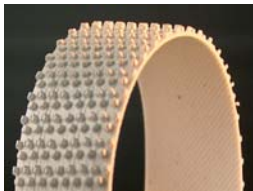

White
 Hardness: 86° Shore

PU Foil Longitudinal Rib

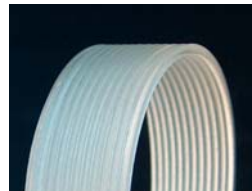

Transparent
 Hardness: 86° Shore

Sprayed PU



Yellow (standard)
 Other colours optional
 Hardness: 50° Shore
 seamless possible
 FDA possible

PU Fishbone



White
 Hardness: 86° Shore

VW = Volumetric weight

Rubber

Linatex

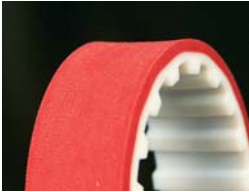

Red
Hardness: 40° Shore

APLN



Red
Hardness: 60° Shore

Linatril



Orange
Hardness: 55° Shore

Linaplus



White
FDA-quality
Hardness: 40° Shore

Rudex

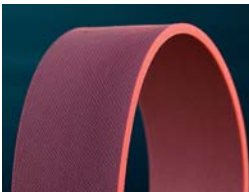

Red
Hardness: 40° Shore

Remaline



Ochre
Hardness: 35° Shore

Orange
Hardness: 50° Shore

Rubber - Supergrip

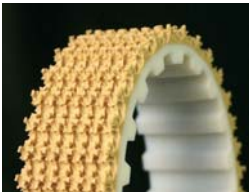

Beige
Black

Rubber - Nipple

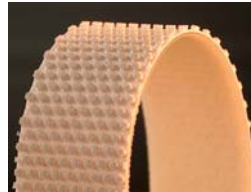

White
Hardness: 40° Shore

Rubber non-skid

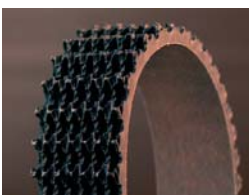

Blue
Supergrip
Non-skid

RP 400



Yellow
Hardness: 40° Shore

Correx



Beige
Hardness: 40° Shore

G / GSTR



Blue
Coarse structure

Rubber

Neoprene

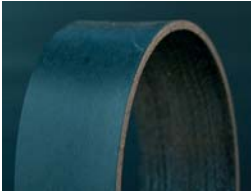

CR/ SBR 63
Black
Hardness: 60° Shore

Neoprene FDA



CR/ SBR 60
Bright
Conform FDA
Hardness: 60° Shore

Perbunan



NBR/ SBR 65
Black
Hardness: 65° Shore

Peruban



NBR 60
Bright
KTW-certification for
contact with drinking water
Hardness: 60° Shore

Porol



Cell rubber CR
Black
Vol.weight: 175 kg/m³

Para

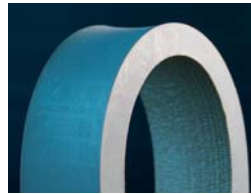

SBR / NR 40
Grey
Hardness: 40° Shore

Textured rubber

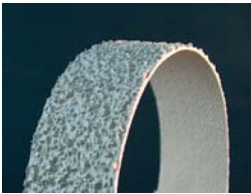

Beige-white

Sponge rubber

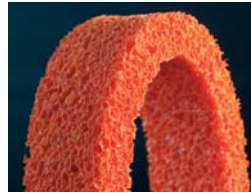

Vol.weight: 200 kg/m³

Viton



Fluoric rubber
Black
Hardness: 75° Shore

Elastomer



Green
Hardness: 65° Shore

PVC

PVC



White FDA
Hardness: 40° Shore
Blue
Hardness: 40° Shore

PVC Sawtooth

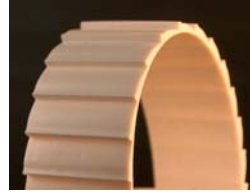

White
Hardness: 40° Shore

PVC Supergrip

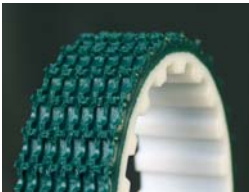

Green/petrol
White

PVC MiniGrip

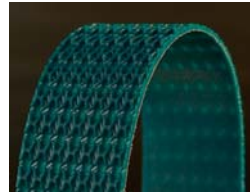

Blue

PVC Fishbone



White
Hardness: 40° Shore

PVC Triangle

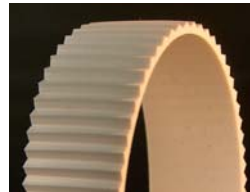

White

PVC Diamond (Waffle)



White

PVC Longitudinal Rib

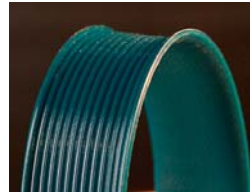

Blue
Black

PVC Nipple

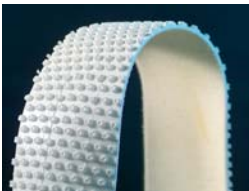

White
Hardness: 65° Shore

Other Coatings

Poly Amide (PA) Fabric



green

Antistatic surfaces



Lacquered black
or PAZ and PAR antistatic

Silicone



Direct coating or on PA fabric.
Transparent

Seamless: hardness: 30°sh
thickness <8mm;
Butt joint: hardness: 40°sh
thickness <10mm;
hardness: 60°sh
thickness <20mm

Novo Felt



Bright grey

Chrome Leather



Silver grey

Wool Felt



On PA fabric
Mottled

PU v-guide smooth

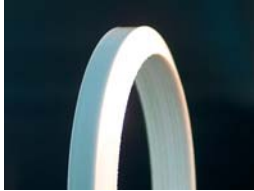

Red / white
Hardness: 85° Shore

Transparent
Hardness: 70° Shore

PU V-guide notched



Red / white
Hardness: 85° Shore

Transparent
Hardness: 70° Shore

Special Coatings

Norditec offers an ever expanding line of unique coatings in addition to the standard coatings listed in this catalog.

Silicone Coating

Neoprene and PU timing belts can be coated with silicone. The silicone can be applied seamless to the belt up to a thickness of 8 mm. The advantages of the silicone coating are its heat resistance up to 220° C, anti-adhesiveness (adhesive and dirt-repellent), its elasticity and excellent durability. The seamless silicone has a hardness of approximately 30° Shore, is transparent and FDA-compliant. Based on its high coefficient of friction it is well suited to transport steel and paper.

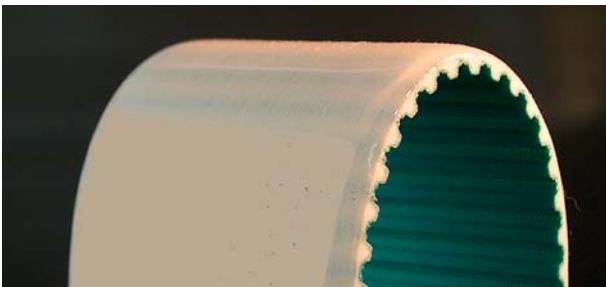

APLN Coating

An APLN coating offers an alternative to the traditional Linatex coating.

APLN has a hardness of 60° Shore. It can be supplied as a coating on endless belts or on



open-ended belts that are supplied per meter. APLN is weldable; it can be made endless by means of a finger joint.

Teflon Coating PTFE

Teflon coating is used when a non-stick or a very low coefficient of friction is needed. Teflon has very good slip characteristics.

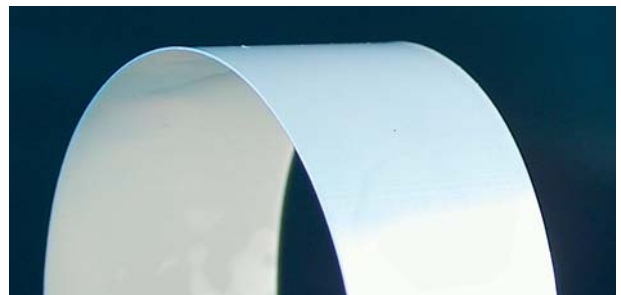

Seamless Polyurethane (PU) Spray Coating

This sprayed polyurethane coating is FDA approved and is wear and abrasion-resistant. The spraying enables a high surface quality with or without grinding and enables a variable cover thickness of 0.2 to 2 mm.

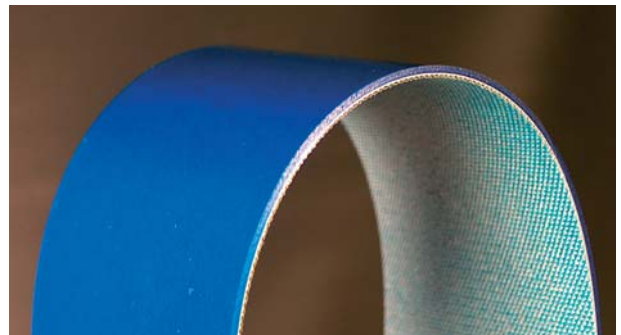

The polyurethane coating is temperature resistant up to 200° F (95° C) with a 82° shore A hardness.

This permanently elastic coating can not only be used for timing belts and conveyor belts, but can also be sprayed on rigid items like rollers, e.g. for noise control and wear protection. The polyurethane can be applied to polyurethane and neoprene timing belts as well as conveyor belts.

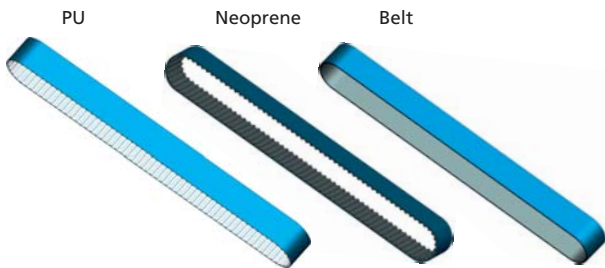

This coating is applied in blue, bright grey, black or yellow.

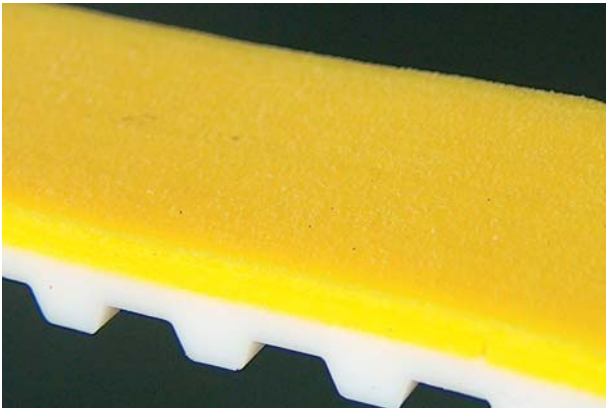

Kevlar Felt Coating

The Kevlar felt coating is applied when very hot objects must be transported.



Applications include, aluminium and steel extrusion and glass product manufacture. The yellow Kevlar felt can withstand temperatures up to 900°F (500°C) (temporarily 1000°F or 550°C). The white Kevlar felt up to 500°F (250°C).

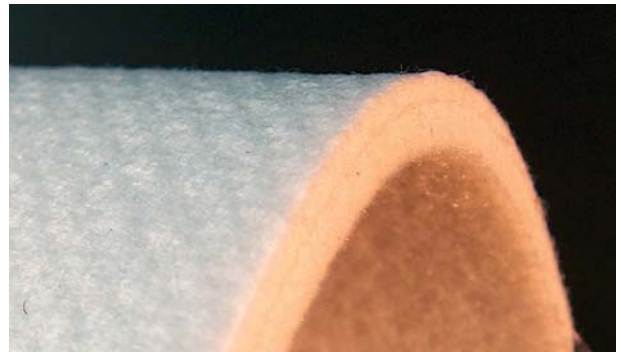

The coating can be applied to open ended or to endless belts. For a higher flexibility thin lateral cuts can be milled into the Kevlar felt.

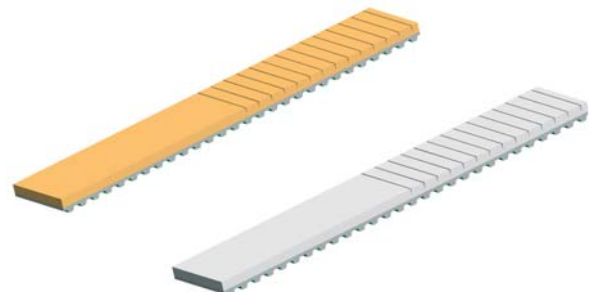

FDA Coatings for the Food Industry

For coatings in the food industry Norditec supplies a variety of different coating materials. Depending on the dimensions and application the coatings can be applied by; welding, gluing or spraying. The coatings shown in this catalog are only a sample of what is offered. For example; the nipple material can be supplied in several versions and belts with sharp stainless steel points are available. Please contact us for more information.

Polyurethane Spikes, light/beige
Thickness ≈ 4mm



Polyurethane Nipple, blue
Thickness ≈ 1.2mm

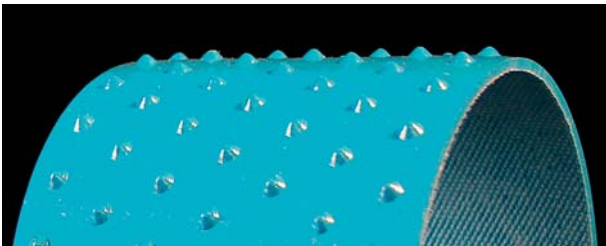

Polyurethane Crossbar
Thickness ≈ 2.5mm

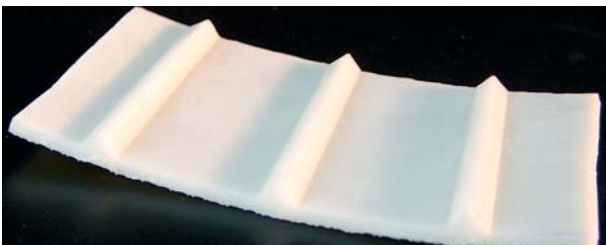

Flat material:

Polyurethane blue and white:
thickness ≈ 1-2mm, 85° Shore A
Rubber white: thickness ≈ 1-10mm,
60° Shore A
PVC white: thickness ≈ 1-2mm, 40° Shore A

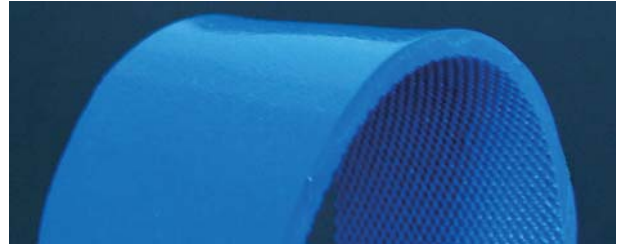

Transparent Silicone Coating

On Polyurethane or Neoprene surfaces.
Thickness up to 8 mm optionally seamless.
hardness: ~30° Shore A

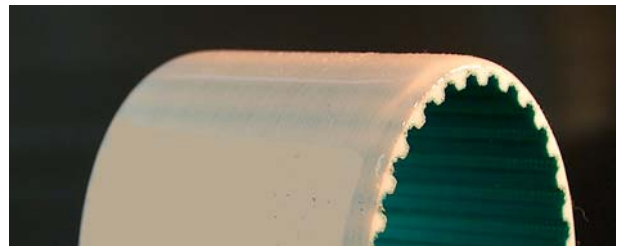

Seamless Polyurethane Spray Coating
On Polyurethane or Neoprene surfaces
bright grey or blue
thickness ≈ 2 mm, 82° Shore A

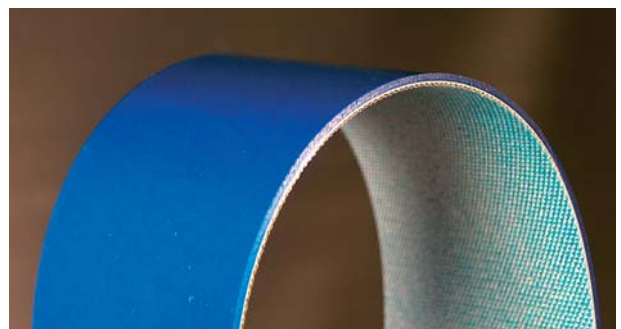

* Polyurethane: up to w=100mm welded, w>100mm glued
PVC and rubber: glued

Coated Conveyor V-belts

V-belts can be coated when products with fragile surfaces are transported such as, wood, ceramics and glass products.

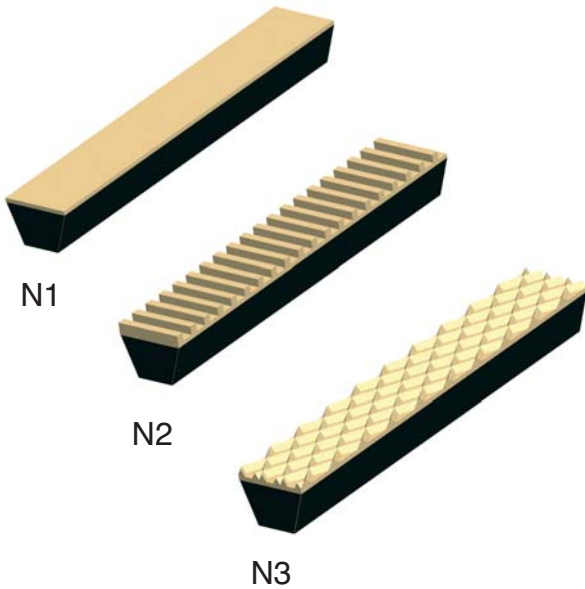

Conveyor v-guides coated with white rubber.

Smooth and textured surfaces are offered depending on the desired coefficient of friction.

Layered Ridgetop V-belts

Layered ridgetop v-belt is a gear belt coated with a v-guide.

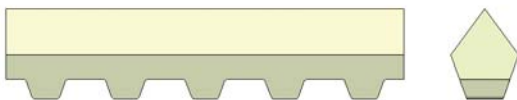

The layered/teeth enables non-slip transmission and synchronous running.

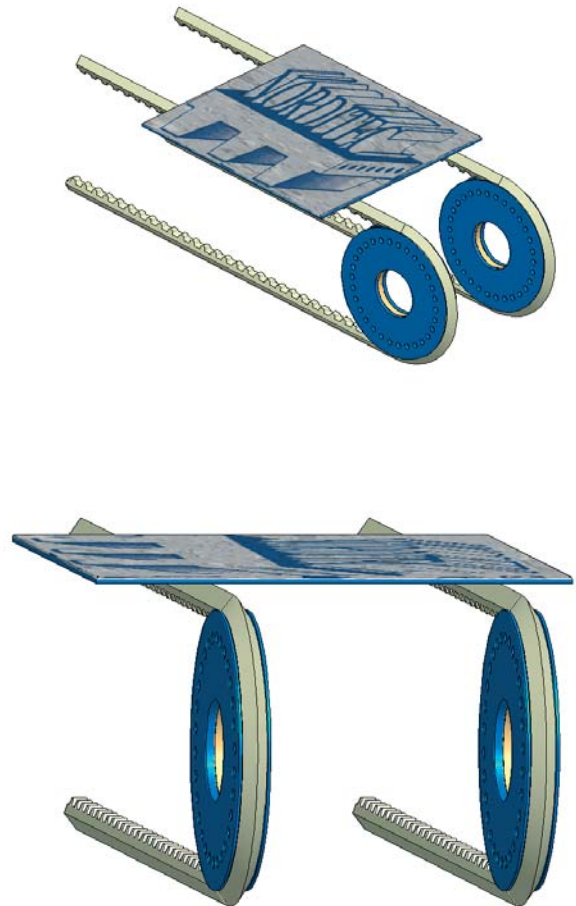

TIP.ASEM - NAME LAYOUT - GROUPE A2

Other Special Solutions

Norditec specializes in the manufacture of uncommon constructions. We can team up with you to find a solution for a special application. For example, Norditec has made belts with robotics on the moving belt surface.

Processing

Guide slots, holes and slits are standard fabrication options. Special fabrication options are available if desired to optimize the effectiveness of the belt to match your specific needs.

The additional processing of untreated and refined belts can be accomplished using the following methods:

- Cutting
- Milling
- Milling with CNC technology
- Grinding
- Punching
- Perforation
- Water-jet cutting

Groves can be added to thick coatings to improve flexibility or increase grip.

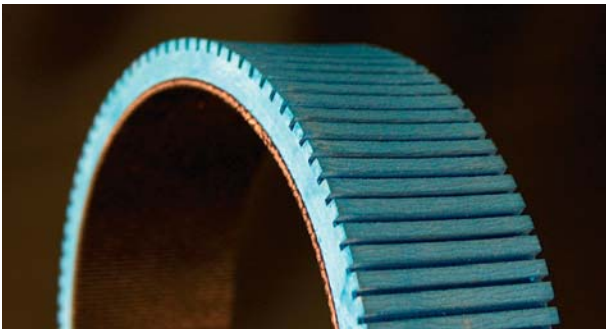

Objects can be easily positioned if placed into grooves on the belt surface.

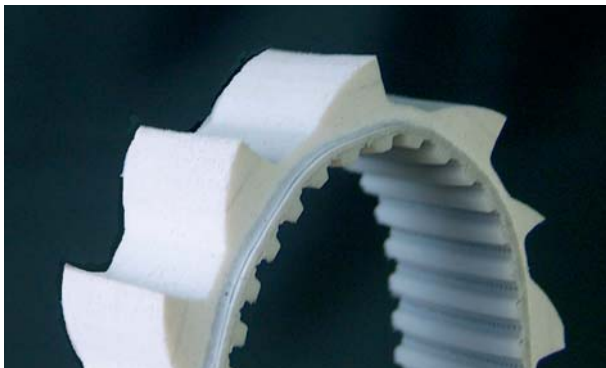

Smooth objects can be more easily transported if the belts are grooved to increase the coefficient of friction.

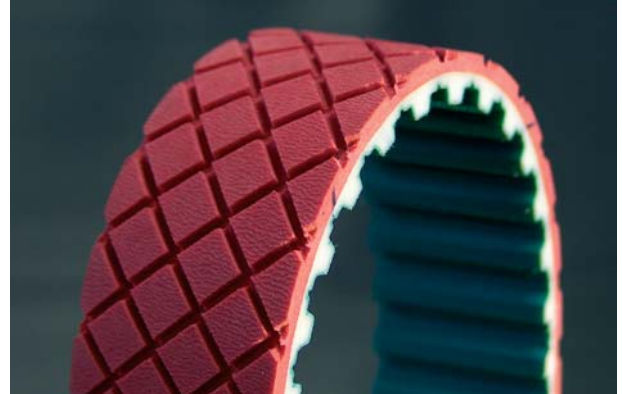

Perforations are used in vacuum as well as other applications.



Dual Timing Belts

A dual timing belt has cogs on both sides of the belt.



Both sides of the belt do not have to be synchronous. Norditec offers belts with different pitches on each side to match your requirements.



A synchronous belt has the same pitch on both sides of the belt. „Vario-Dual“ timing belts have different pitches on the inside and outside of the belt.

A „Multi-Vario-Dual“ timing belt has various pitches on one side of the belt as well as on the inside and outside of the belt.

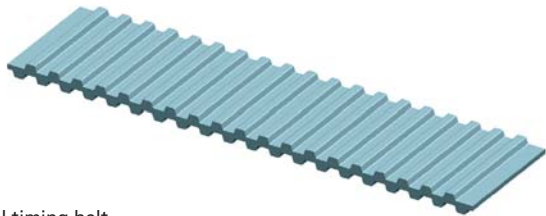

Dual timing belt

Top T10
Bottom T10

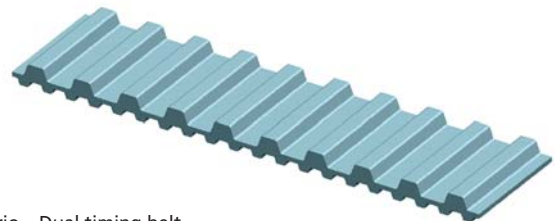

Vario – Dual timing belt

Top T10
Bottom T5

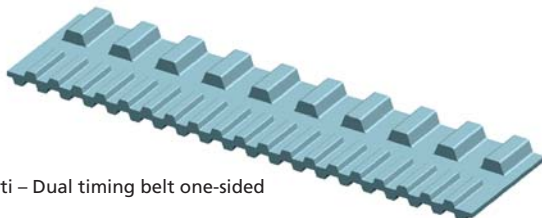

Multi – Dual timing belt one-sided

Top T5 and T10
Bottom T5

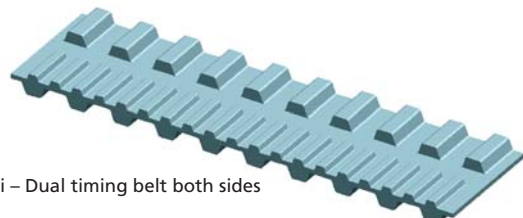

Multi – Dual timing belt both sides

Top T5 and T10
Bottom T5 and T10

Vacuum Timing Belts

A vacuum timing belt is a belt with slots and/or holes on the back of the belt. Vacuum belts are usually used in the packaging industry. They enable efficient transportation of light pieces goods such as paper as vertical removing of foils.

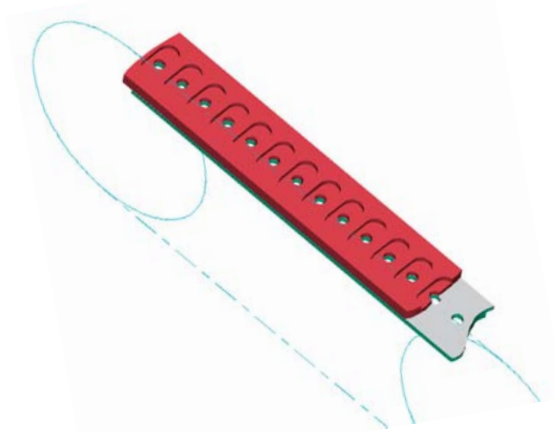

Norditec can apply all coatings to vacuum belts. CNC milling machines ensures precise placement of slots and holes.



Many different configurations are listed in our "Vacuum Belts" catalog, however as with all Norditec belts most are custom made to your specifications.

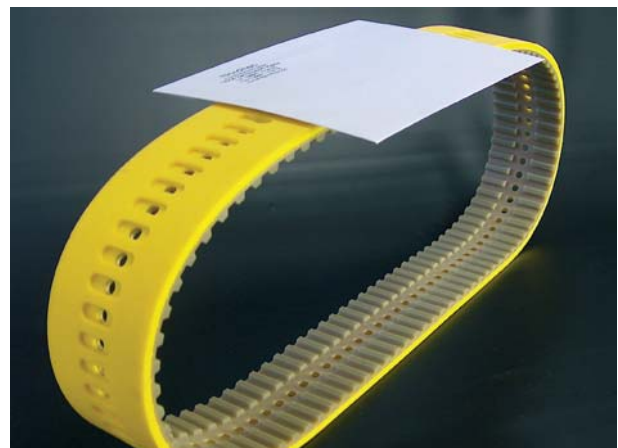

Cam Belts

Cam belts/cleat belts are used for conveying piece goods requiring fixation of the product during transportation.

Norditec's continuously expanding „Cleat Catalog“ has over 300 stock cleat cam designs. Just ask and a catalog will be sent.

The demands of a cleat are usually very specific. Together we will find a solution to your specific needs.

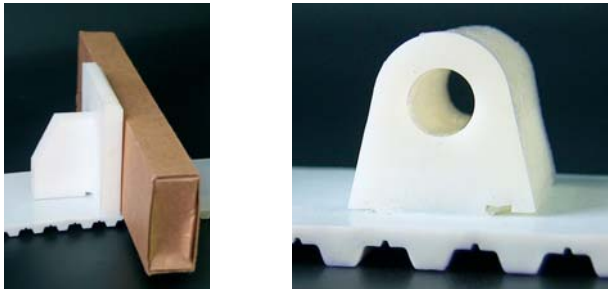

Custom cams will be made to your drawings if a stock design is not available.

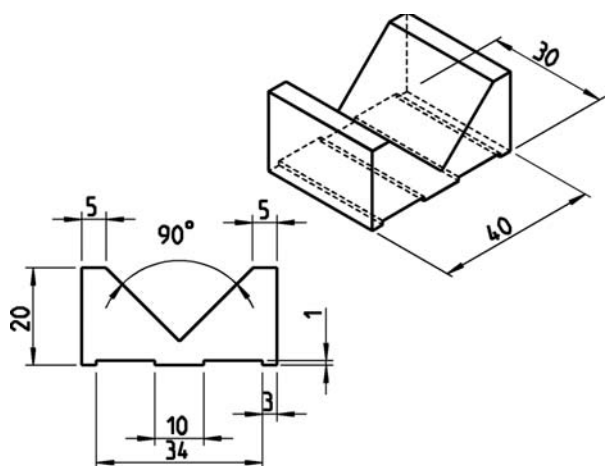

We will supply whatever cam you require for your most demanding applications.

Cams are made in our in-house injection molding machines and machining centers.

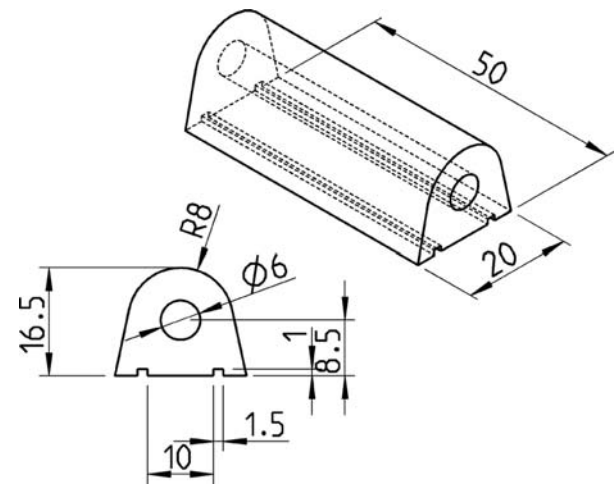

The cams are welded to polyurethane belts. Norditec also offers a removable-cam system. (See „Removable-Cam Systems.“)

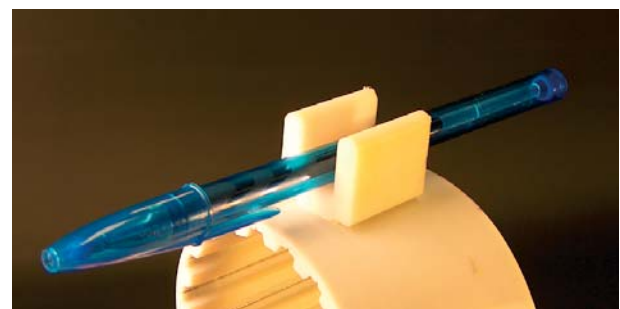

An example of our continued research and development, Norditec offers a magnet mounted cam system. (See „Special Solutions.“)

Removable-Cam Systems

The removable-cam system enables quick replacement of cams at all times, especially when the belt is first fitted. This reduces installation and replacement costs.

The cam material and pitch between cams is flexible, keeping in mind the pitch of the cogs.

Two types of the removable-cam system are available:

Removable-cam system Type – N

A fitting key is inserted in the cam.

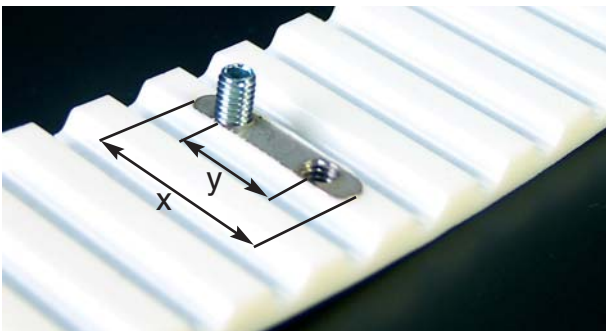

Cogside view

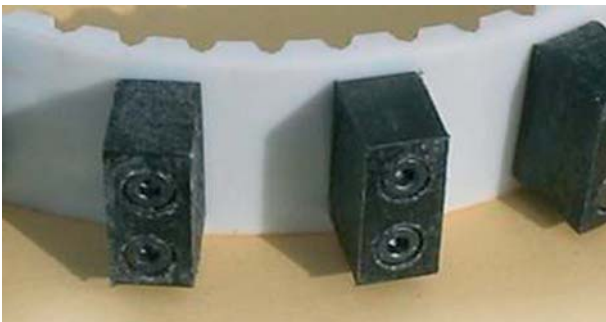

Bottomside view

In the following table the standard sizes are indicated. Other sizes are available on request.

Pitch	Width [mm]	X [mm]	Y [mm]
AT10	12	10	5
	25	22	12
	32	22	12
	50	35	25
	75	60	2x25
AT20	50	45	25

Removable-cam system Type – M

For Type – M the entire cog is milled off and an insertion bar is fitted.

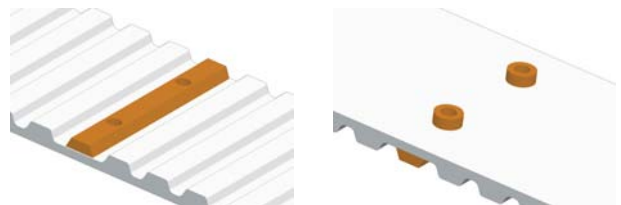

Depending on the width of the timing belt the insertion bar has one, two, three or four thread inserts (see table below)

Pitch	Width Belt [mm]	Type Screw	Quantity Screw	Distance Screw [mm]
AT10	32*	M4	2	20
	50*		2	
	75		3	25
	100		4	
AT20	25	M5	1	-
	50		2	25
	75		3	
	100		4	

Available in brass or plastic.

* Also available in plastic without thread inserts.

Pocket Timing Belts

Pocket timing belts are characterised by the long, flat tabs that are attached to the belt. These belts are used, for example, in conveyance of hygiene products such as baby diapers.

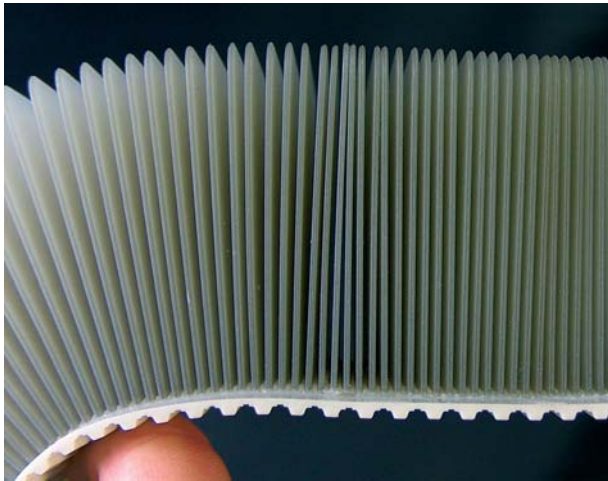

Starting at a pitch of only 0.08 inches, (2 mm) this is another example of our continuing research and development efforts that make Norditec a world leader in conveyor belt technology.

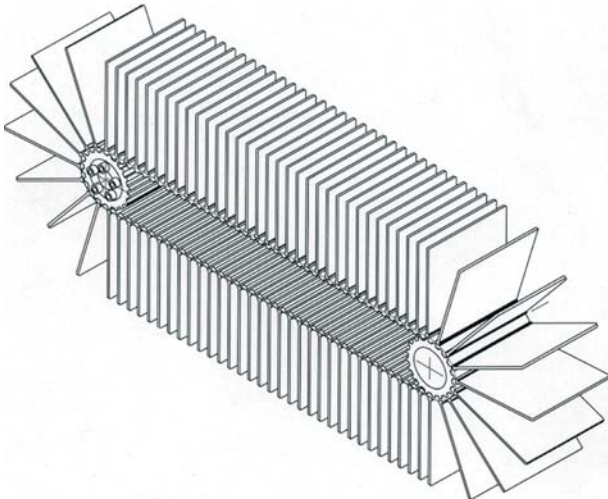

The cams are molded in-house from glass-filled nylon. This enables Norditec to maintain the stringent quality that is required to manufacture cams that are thin and durable.

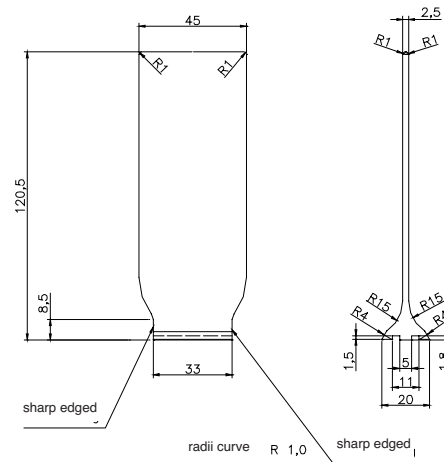

Please call for a complete catalog of our many different cams.

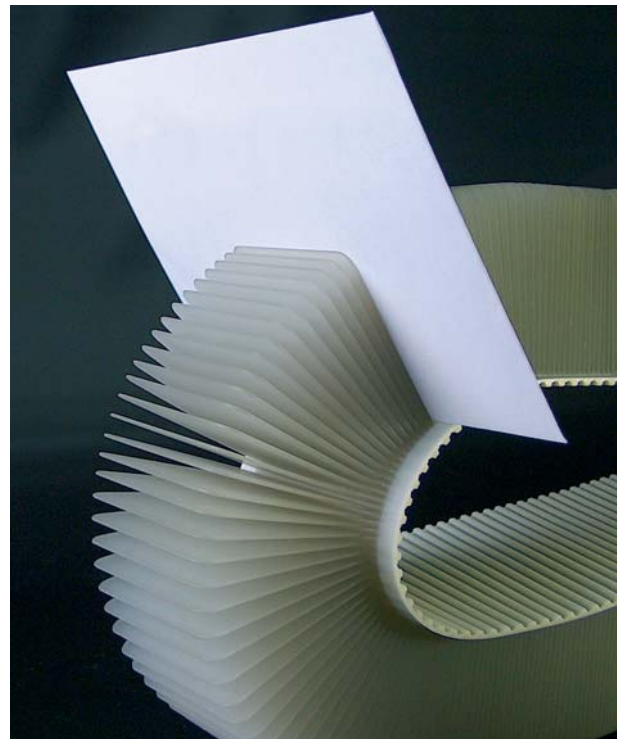

Special Solutions

Norditec is well known for its unique solutions to solve difficult conveying requirements. We will work with you to find a solution to "our" problem.

Wide Polyurethane belts

Wide timing belts, with widths up to 500 mm, are currently only available in the market fitted with Kevlar cords. Norditec can produce wide timing belts with kevlar or steel cords.

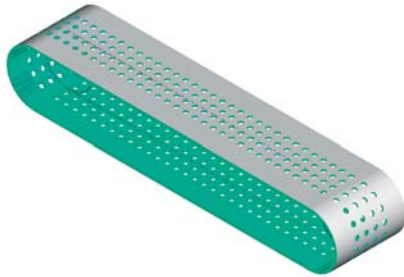

Wide silicone coated timing belts with perforations

Several different belts can be joined together to form one wide belt with synchronized teeth.

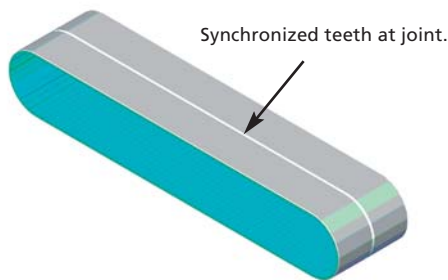

Wide PU timing belt

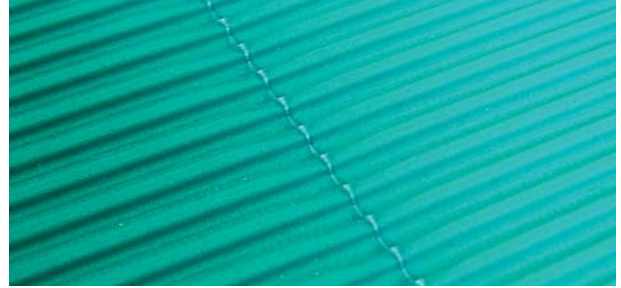

Wide PU timing belt with synchronized teeth at the joint.

Available sizes:

Pitch	Max. Width
T5	400 mm ~16"
AT5	400 mm ~16"
T10	400 mm ~16"
AT10	400 mm ~16"
H	18" = 457,2 mm

For widths up to 1,000 mm a HV-foil is welded to the surface allowing Norditec to reach this width.

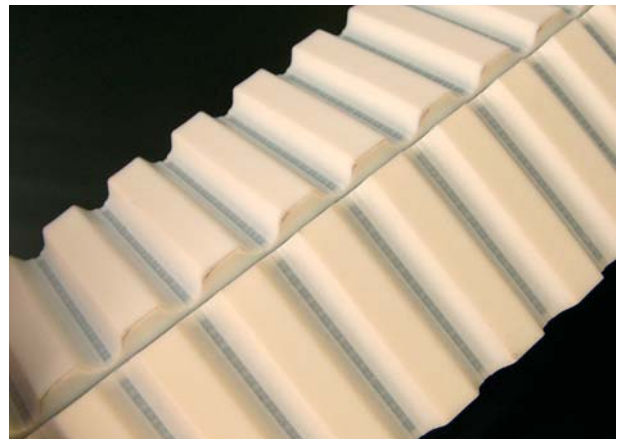

Wide timing belts with welded-in HV-foil.

Magnetic Timing Belts

Another example of Norditec's continuing to lead in technological advancements, in conveyor belt development, is magnetic belts.

The magnetic belt enables selected positioning of metal parts based on the orientation and position of the magnets inserted into the belt.

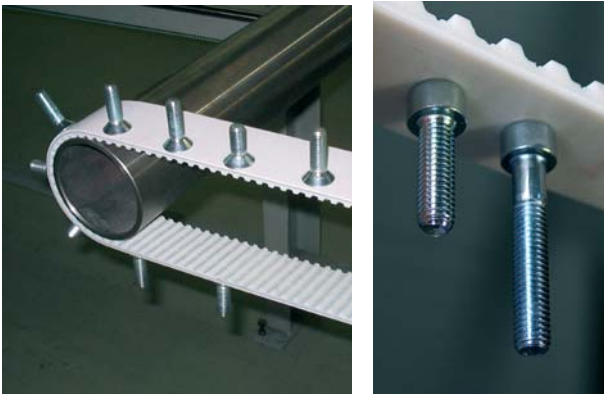

We apply the magnets to the surface of the belt according to customer specifications, with strength, polarization and orientation to match your requirements.

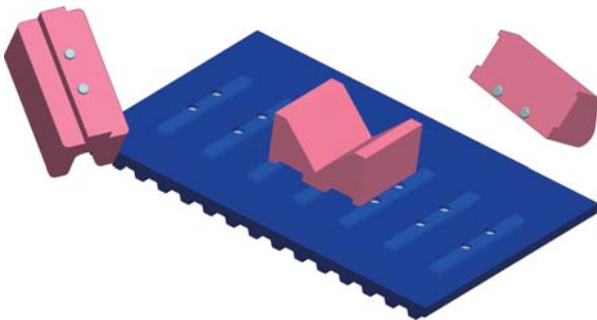

Form-fit rapid-exchange system for various types of cams

Magnetic belts, like all of Norditec's belts, can be supplied with a variety of surfaces to match your requirements for friction or any other desired physical properties.



The attractive force of the belt is variable depending on the orientation and polarization of the magnets. Either repulsion or attraction of the magnets can be utilized to meet your requirements.



In addition to the classic transportation of metal parts the belt can also be used for conveying paper and foils, in which the transported goods are clamped in between two tightening belts or between a low-friction surface and the magnetic belt.

Water-jet Cutting

Utilizing water-jet cutting Norditec can cut any shape in the belt that the customer desires.

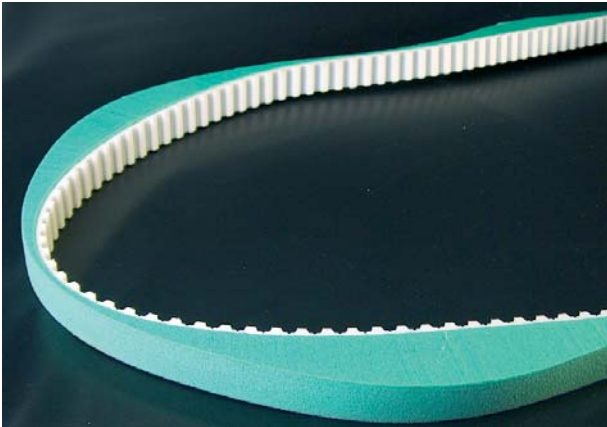

The water-jet cutting allows precise holes and slots to match your specifications.

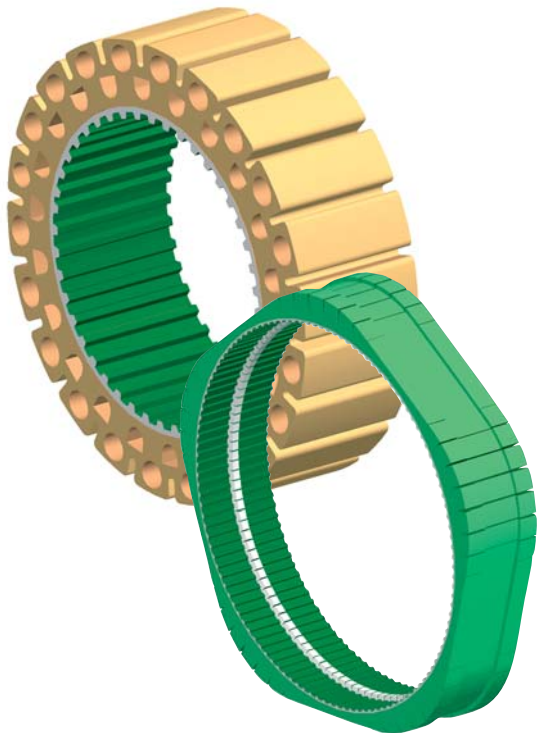

Timing Belt Robotics

Norditec is proud to introduce patented robotic belt technology to the automated manufacturing world.

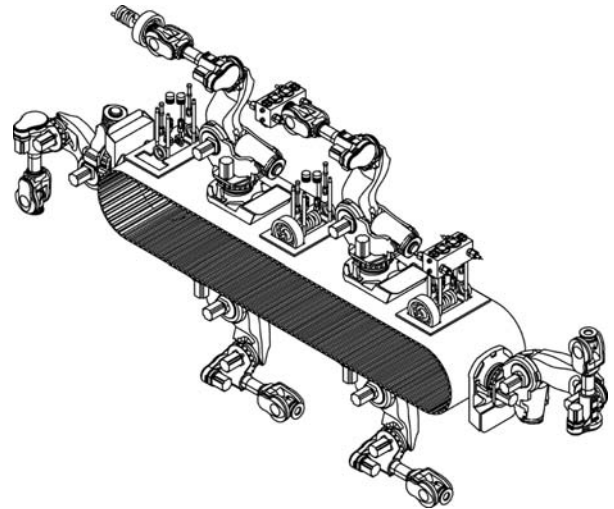

For example, robotic grippers can be placed on the timing belt to facilitate grasping of objects.

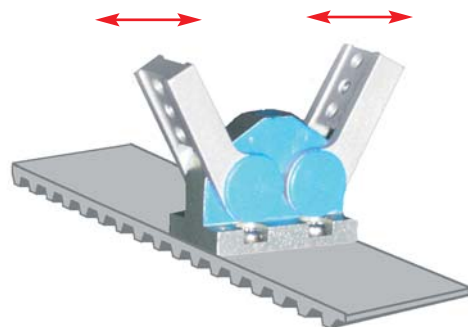

Detachable Belt Fasteners

In many cases it is virtually impossible to install a belt after the machine has been assembled. In these cases Norditec offers belts that can first be fitted to the machine and then be connected together after installation.

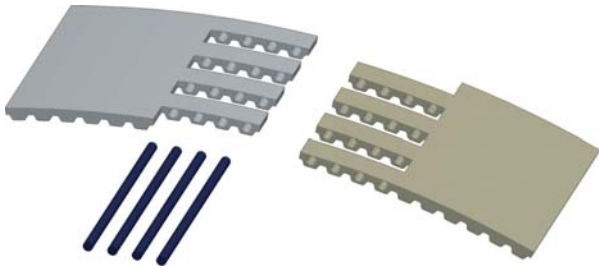

Various methods to join and disconnect belts after installation are offered.

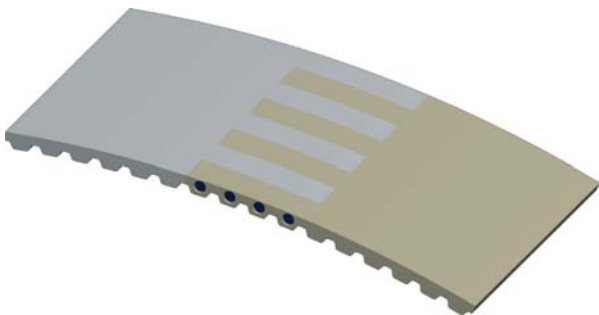

Belt assembly equipment

Portable cutting machines and welding presses

We supply belt “finger” cutting machines and welding presses to the end user. This allows the customer to cut and weld installed belts on-site.

A hand operated press cuts fingers into the belt.

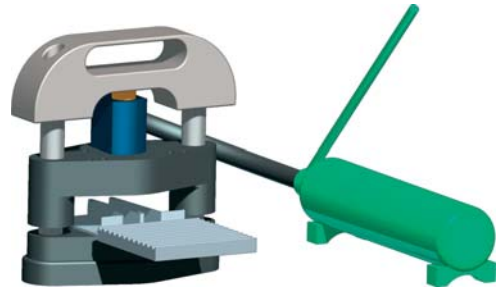

The finger joint increases the strength of the weld due to the increased surface area.



A portable welding press then welds the finger joint together.

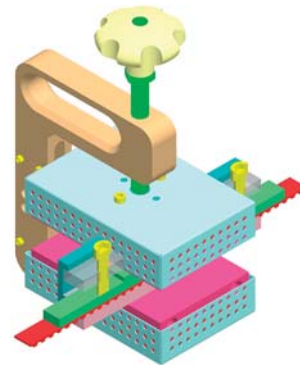

Standard timing belts

Norditec also offers unmodified timing belts, toothed pulleys and Poly-net.

Services

Water-jet Cutting

In addition to using water-jet cutting to customize belts, Norditec also offers general water-jet cutting services.



NORD

The abrasive-jet process enables the handling of the most diverse materials. Even metals and plastic foams can be neatly cut.

Material up to 1.2 m X 1.2 m and up to 150 mm thick, depending on the material, can be cut with the water-jet cutting machine.

Polyurethane Spraying

We offer sprayed PU panels. The sprayed product has a hardness of 50° Shore. The standard panel measures 500 x 5,000 mm and can be supplied in thicknesses 2, 3, 4, 5, 6, 8 and 10 mm. Further non-standard panel thicknesses can be supplied on request. Please contact us for a copy of our pricelist.

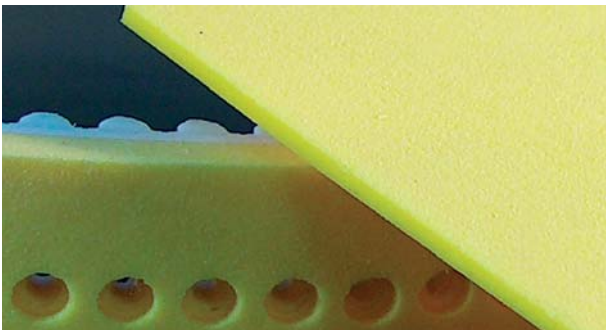

Antistatic measurement

In many industrial sectors electrostatic charging of timing belts is undesirable. (For example, the conveying of sensitive electronic components or in areas where the chance of explosion exists.) Antistatic characteristics of the belts are achieved by application of an electrical conductive coating on the belt surface. For this purpose the belts must be coated with a polyamide fabric. (NFT/NFB or PAZ/PAR) The resistance can be further reduced by coating with a special anti-static rubber that can reach values below 10 (with exponent to 6th power) Ohms. According to DIN 22104 "Antistatic Conveyor Belts" the surface resistance must remain below 3×10^8 Ohm.

The electrical properties of belts will be measured upon request.



As the conductiveness of the coating can diminish with age regular measurement is advisable. Measurement is carried out according to DIN EN 61 340-2-3 and DIN EN 340-4-1. A digital high-ohm meter is used for this purpose.



Norditec USA LLC

6427 Ithaca Lane North
Minneapolis, Minnesota 55311-4148
Phone: 763-550-9063
Fax: 763-550-0506
e-mail: kroll@norditec-usa.com
Internet: www.norditec-usa.com

Norditec Europe

e-mail: kontakt@norditec.de
Internet: www.norditec.de

